



# EPEVER

## IT/ET-NC G3 Series

### Solar Controller Introduction

# 目录

## CONTENTS

01

【Overview】

02

【Specifications】

03

【Others】



# Overview

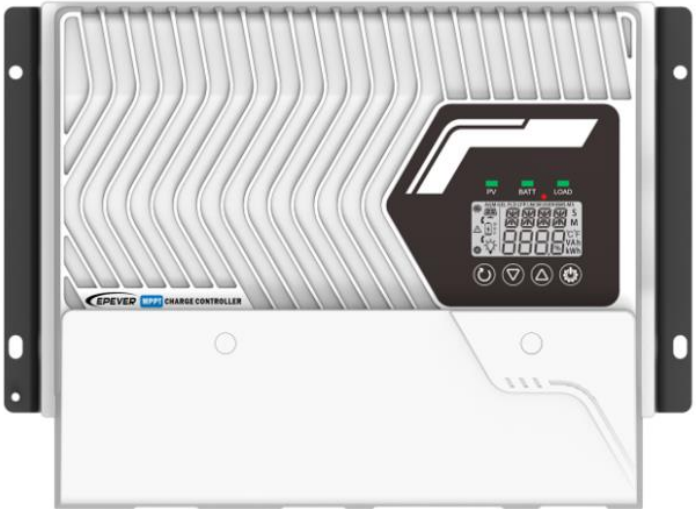

New Generation

# IT/ET-NC G3 Series

High current MPPT Solar Controller



- 12V/24V/36V/48V system voltage level
- 50A~100A rated charge/discharge\* current
- 150V/200V PV Maximum Open-circuit Voltage
- 80A, 100A models support 2 MPPT input
- Supports 6 devices work in parallel
- Discharge while charging\*, multiple load modes

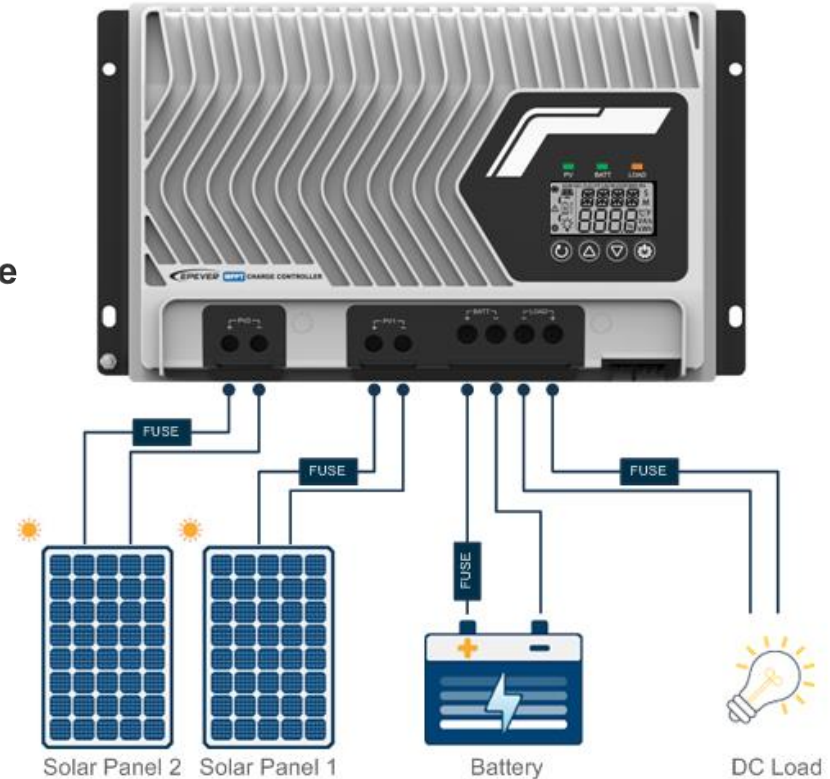

# Model



**IT 10 4 20 N C G3 BLE**

BLE\*: Built-in Bluetooth

G3: The 3rd generation

Monitor: C-LCD screen,  
E\*-LED indicator

N: Common negative system,  
P\*: Common positive system

PV Max. Voc: 15-150V, 2-200V

Battery Rated Volt.: 4-12V/24V/36V/48Vdc

Rated charge/discharge\* current:  
5-50A, 6-60A, 7-75A, 8-80A, 10-100A

Name: IT series(with load),  
ET series(without load)

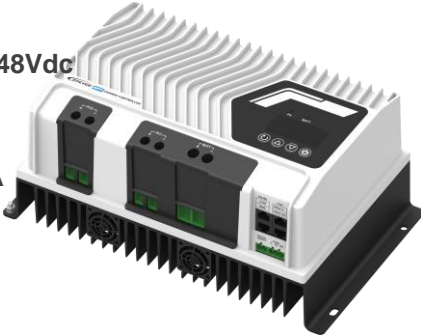
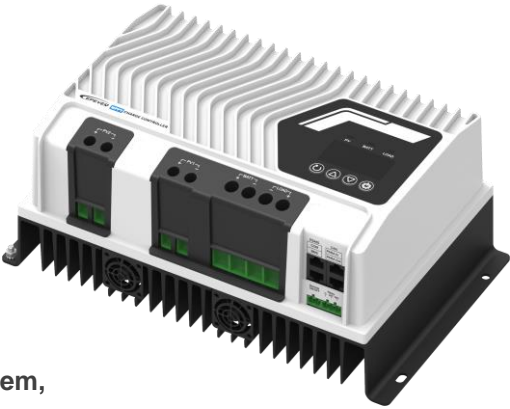

# Appearance



CAN parallel com port: Support 6 devices parallel (with/without battery) work, flexible extension

Isolated RS485 com port: FW upgrade, optional Bluetooth, WIFI, RTU 4G modules to achieve wireless monitoring



RTS/BMS com port: optional BMS-Link module or RTS-D47K tem. sensor, realize safe and reliable control of battery

PV Charge control switch: ① Without cutting off PV cables for battery maintenance or replacement;  
② Battery can control the PV charge directly via its dry contact

Relay-generator dry contact port: Smart control of auxiliary charging equipment start and stop



# Specifications

- 1.MPPT charge: Some models support dual PV inputs, tracking efficiency  $\geq 99.5\%$ , conversion efficiency up to 98.5%
- 2.Constant Voltage Output Function: Enables direct load supply with sufficient PV energy without battery
- 3.Multi-unit parallel: Support 6 units parallel (with/without battery) work, flexible extension
- 4.Battery Types: Provides stability and compatibility for various Lithium-ion and lead-acid batteries
- 5.RTS/BMS com:With BMS-Link or RTS-D47K temperature sensor, ensure accurate charge/discharge control of the battery
- 6.Load output: 6 control modes to meet multiple scenarios
- 7.Built-in Bluetooth: Some models built-in Bluetooth module, APP convenient monitoring and management
- 8.Local monitor: The LCD can set most of the control parameters, make the system monitor and setting more convenient
- 9.Remote monitor: Isolated RS485 com port for FW upgrade, Or optional Bluetooth, WIFI, 4G modules to achieve wireless monitoring
- 10.Data Log: With real-time data, events and accumulated power save function, 15000 storage capacity, full capacity cycle coverage
- 11.Work environment: Full load operation in  $-25\sim 40^{\circ}\text{C}$ , high temperature charging will automatically reduce power
- 12.Low static loss  $< 0.05\text{A}$ , long system standby time
- 13.All-metal die-cast housing with IP43 high protection level
- 14.IEC62109、UL1741、EMC standard design, with comprehensive electronic protection functions

# 1.MPPT Charge

- Dual PV inputs, tracking efficiency  $\geq 99.5\%$ , conversion efficiency up to 98.5%

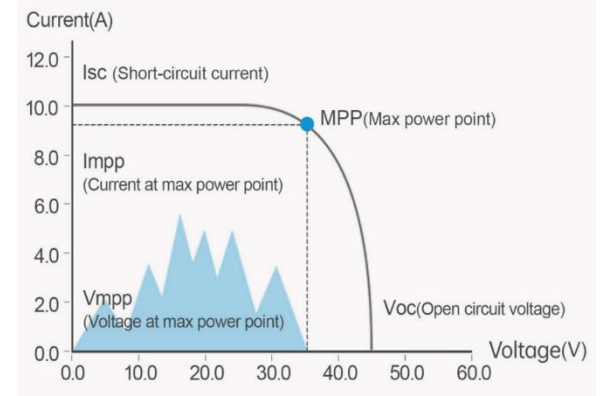
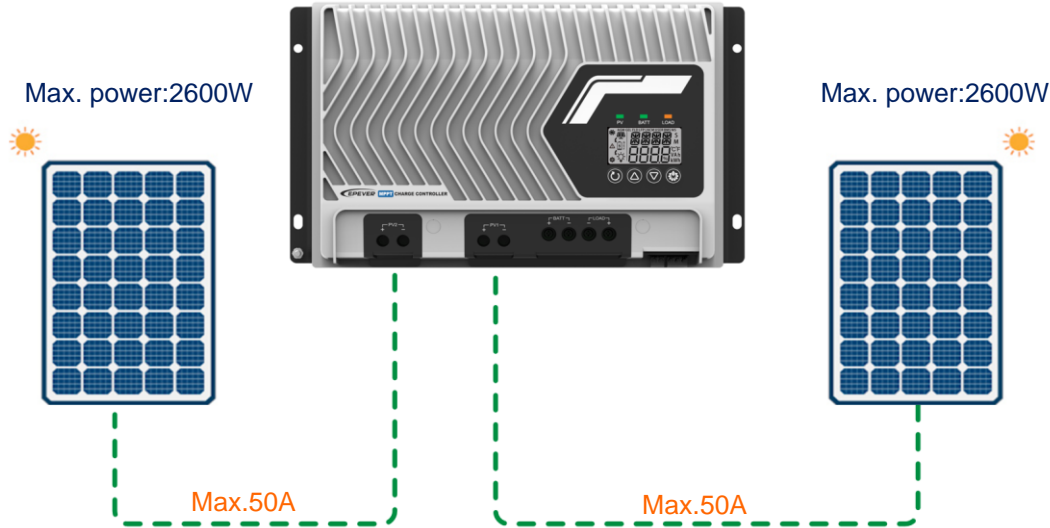

- Only 80A and 100A models support 2 PV inputs, can be set to Centralize (2 merge into 1) or independent.
- The min. PV input voltage: Battery voltage + 2V and must be higher than 28V
- The efficient MPPT tracking technology maximizes the power generated by the solar panels to provide more power to the system

# 1.MPPT Charge

- Dual PV input, the diagrams of different PV mode Settings

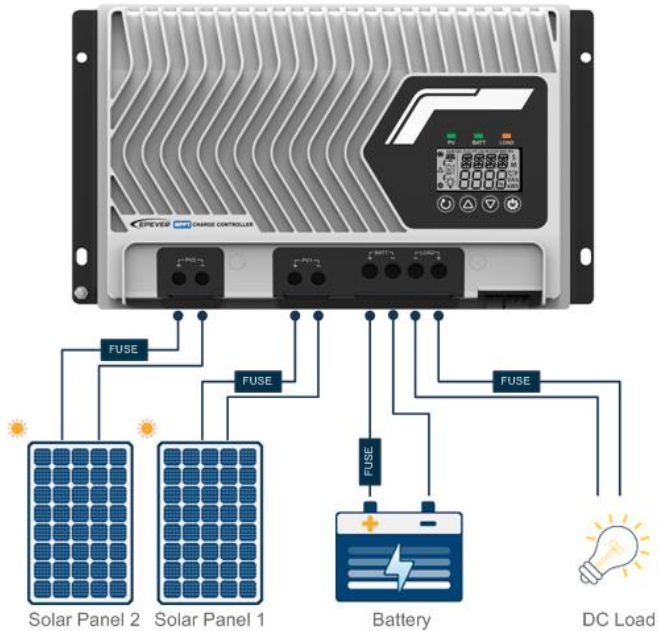

INDE Mode

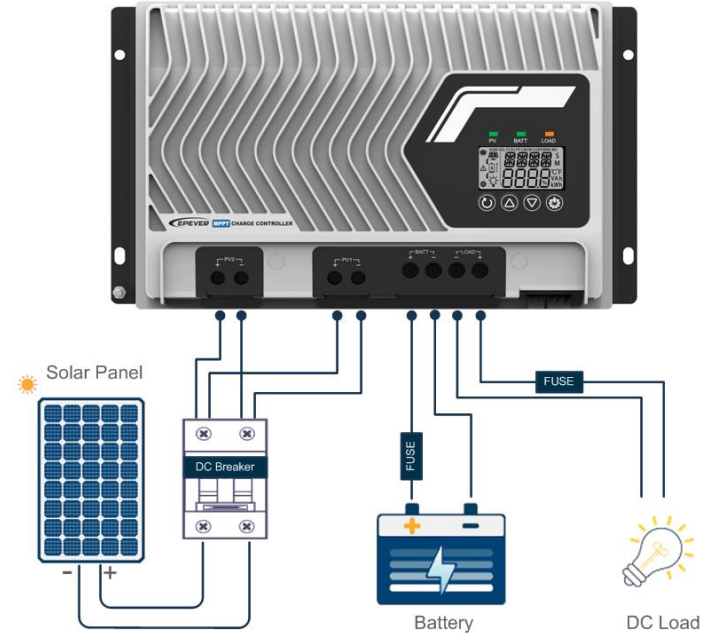

CEN Mode

- Set to independent mode, 2 PVs can be of different specifications, different orientations, and different connection modes.
- Set to centralize mode, need external parallel connection

# 1.MPPT Charge

- With external PV charging control switch, easy battery maintenance ;
- Battery (with dry contact output) can also control PV charging/discharging

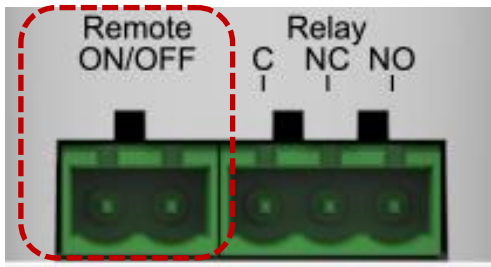
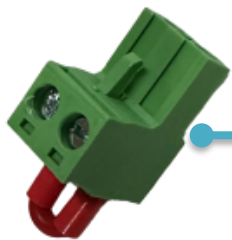

Charge Enable Terminal

- "Charge Enable Terminal" is the standard accessory
- When parameters "CPE (COM Port Enable)" and "ROT (Remote ON/OFF Terminal)" are set to ON, you can control PV charging by plugging or removing the "Charge enable terminal";
- When parameters "CPE (COM Port Enable)" and "ROT (Remote ON/OFF Terminal)" are set to OFF, the PV of the device is valid for charging by default, and "Charge enable terminal" can't control PV charging or not.
- Users can maintenance or replacement battery by unplugging this terminal, and without changing PV connection, more simple and convenient.
- Battery (with dry contact output) can also control PV charging/discharging.

# 2.Constant Volt Output

➤ Enables direct load supply with sufficient PV energy

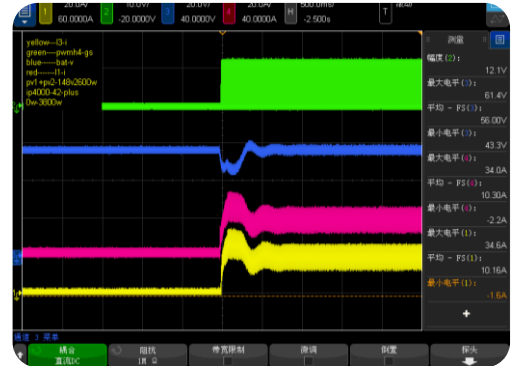
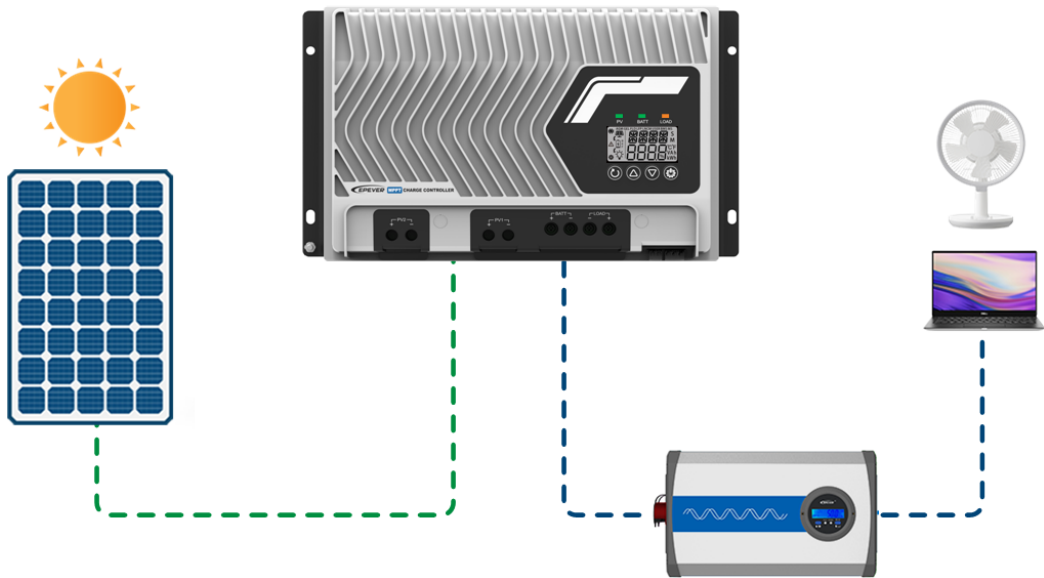

- When Constant Volt. Output (without batteries or battery is disconnected by protection), the PV can run the load connected to the battery through the controller if the PV energy is sufficient (real-time  $P_{PV}$  > peak  $P_{Load}$ )

# 3.Multi-unit parallel

## ➤ Support 6 units in parallel (with battery), flexible extension

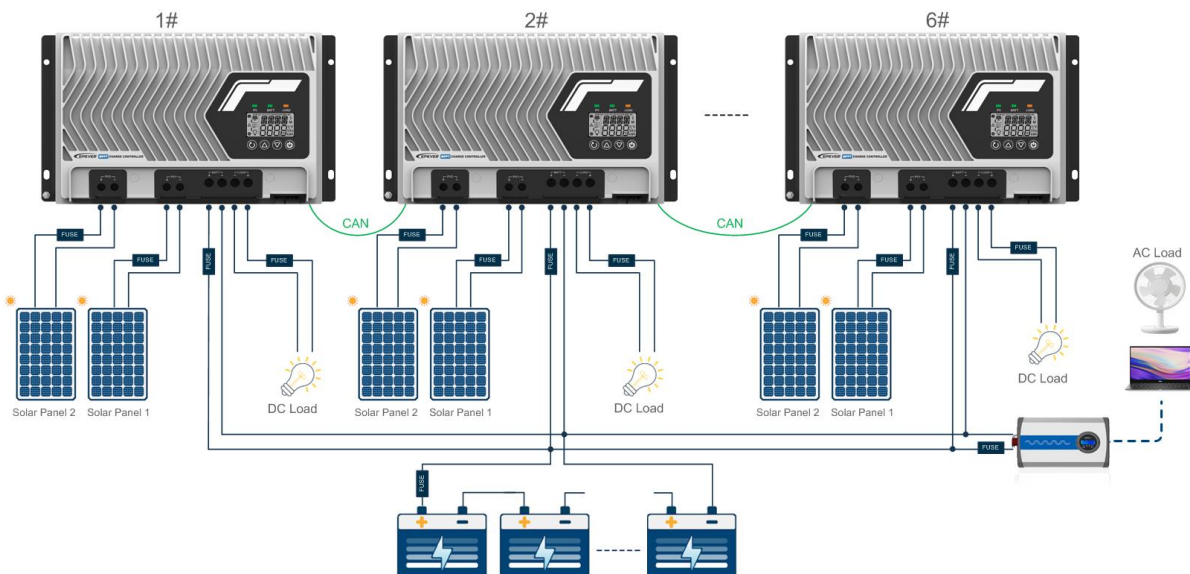

- In parallel application, the PV side and load side of each controller must be independent.
- In the same parallel system, the product model must be the same, but the ID must be different.
- Parallel communication cable must be connected between parallel units, and the parallel communication ports of the first and last controllers need to be connected to the terminal resistor . Communication cable (CC-RJ45-RJ45-120) and terminal resistor (RJ45-CAN-R120) are optional;
- The parallel communication cables do not cross with the PV, battery input cables or AC output cables, otherwise the parallel communication may be interfered.

Note: See the user manual for more details.

# 3.Multi-unit parallel

## Support 6 devices in parallel (without battery), flexible extension

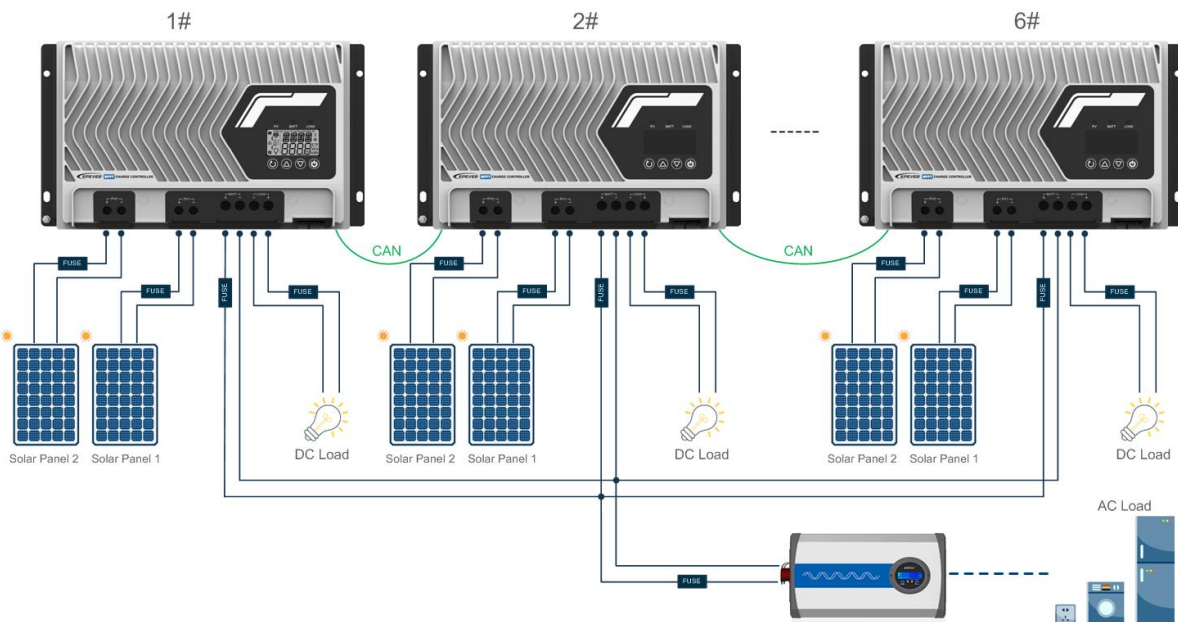

- In parallel application, the PV side and load side of each controller must be independent.
- In the same parallel system, the product model must be the same, but the ID must be different.
- Parallel communication cable must be connected between parallel units, and the parallel communication ports of the first and last controllers need to be connected to the terminal resistor . Communication cable (CC-RJ45-RJ45-120) and terminal resistor (RJ45-CAN-R120) are optional;
- The parallel communication cables do not cross with the PV, battery input cables or AC output cables, otherwise the parallel communication may be interfered.

Note: See the user manual for more details.

## 4. Battery Types

➤ Provides stability and compatibility for various Lithium and Lead-acid batteries

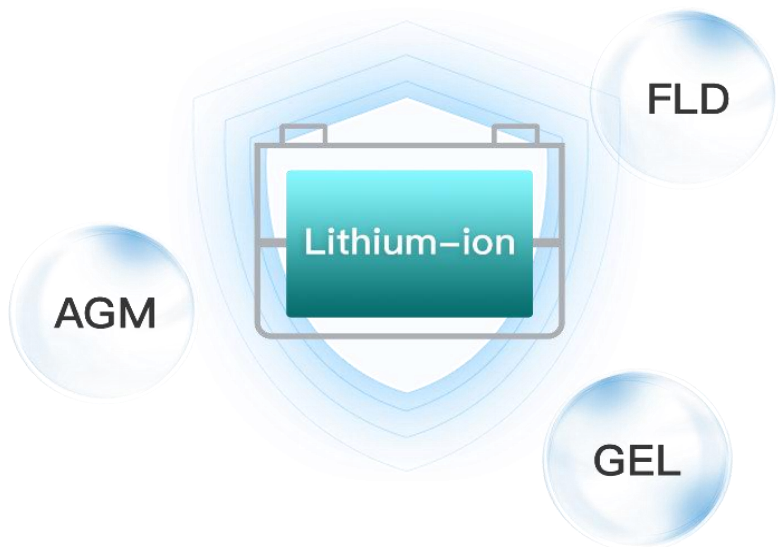

- **Output Overcurrent Protection** prevents damage caused by load short circuit faults on the battery side or the activation of impact loads during PV activation of lithium batteries.
- **The peak output voltage protection value will vary depending on the set system voltage level**(12V system  $\leq 18V$ , 24V systems  $\leq 33.5V$ , 48V system  $\leq 63.5V$ ), to prevent excessive overshoot voltage that could damage the load or lithium battery.

# 5.RTS/BMS Com



## BMS-Link module, ensure accurate charge/discharge control of lithium battery

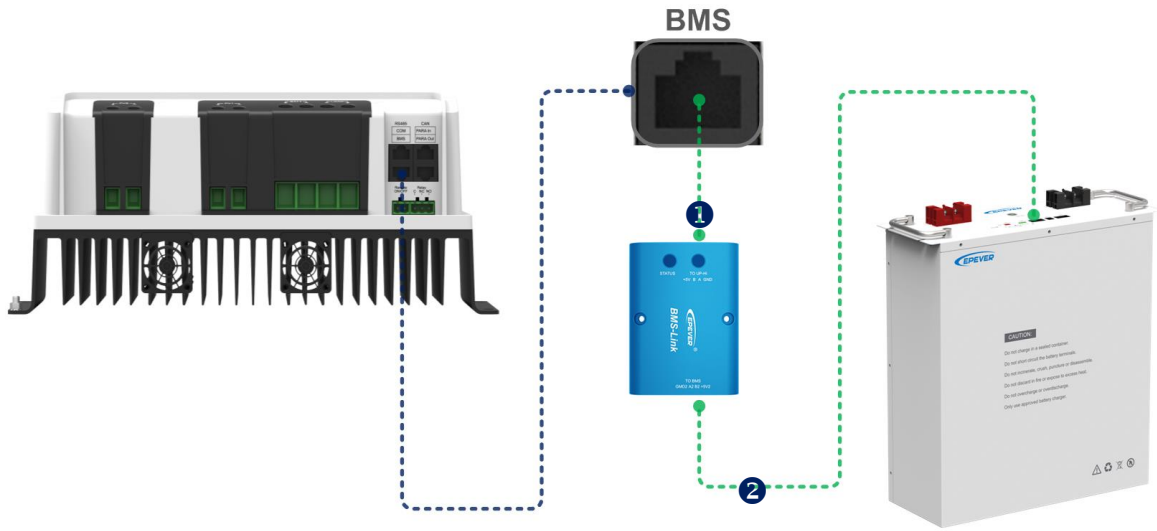

- 33 lithium battery protocols compatible;
- EPEVER battery or some Pylontech battery can communicate directly. Other brands of batteries need to buy BMS-Link module;
- BMS parameters can be used in display and charging/discharging management, Lithium battery charging/discharging and protection more timely and accurate;
- Cable ① is included accessory of BMS-Link module, cable ② needs customized according to the battery or made by clients

### 1. Supported BMS communication protocols

PRO	Manufacturer	Protocol Name	Protocol Type	Fixed ID
1	Narada	SHINWA BMS ModbusV1.3_181127EN	Modbus	0x27
2	Narada	Narada lithium battery BMS communication protocol V1.8	Encrypted Modbus	10x01
3	LinkData	PACE BMS Modbus Protocol for RS485 V1.3(2017-06-27)	Modbus	10x01
4	LinkData	Updated - BMS protocol_V2_0 (compatible with BMS009_customised(20190225))	Telecom	0
5	Saaredun	Topband RS485_RS232 BMS protocol V1.4	Telecom	2
6	Ritar	RS485_RS232 BMS Communication Protocol RITAR(1)	Telecom	2
7	Saaredun	485 Modbus Protocol V1.3	Modbus	10x01
8	Ritar	Modbus-BMS-protocol V1.6	Modbus	1
9	Sunnew	Sunnew x20xP ESS Protocol V1.0	Modbus	1
10	EPEVER	EPEVER_BMS_RS485_Modbus_Protocol V1.6	Modbus	4
11	PYLONTECH	RS485-protocol-pylon-low-voltage-V3.3-20180321	Telecom	2
12	MERITSUN	RS-485 Communication Protocol	Telecom	2
13	FOXESS	LV Battery RS485 Protocol	Telecom	2
14	AOBO	AOBO battery 485 Comm. protocol for BMS Inverter or EMS	Modbus	1
15	MERITSUN (BRAZIL)	LupowerMk Battery Protocol RS485_V01	Modbus	1
16	UNICORA	Modbus Communication Protocol -LPLFP48-v2 (Communication baud rate 19200)	Modbus	1
17	EverExceed	RS485 protocol-EverExceed-low-voltage-V3.5	Telecom	12
18	Shanghai energy	BMS Communication Protocol_V2.0	Telecom	1
19	Dyness	Modbus Protocols for Inverter	Modbus	1

20	UNICORA	Modbus Communication Protocol -LPLFP48-v2 (Communication baud rate 9600)	Modbus	1
21	PYLONTECH	RS485-protocol-pylon-low-voltage-V3.5-20191223	Telecom	1
22	JIN YUAN HUAN YU	BMS Communication Protocol_V2_6	Telecom	1
23	OUTLER	OUTLER BMS Communication Protocol	Modbus	1
24	Sunstone	Sunstone BMS-485	Modbus	1700xAA)
25	TOPBAND	BMS Modbus Protocol for RS485 V1.5	Modbus	1
26	Voltionic Power	Inverter and BMS 485 communication protocol Ellis/Lory/Jenny	User Define	1
27	EPEVER	low voltage protocol RS485 V1.0	Telecom	1
28	PYTES	PYTES battery protocol RS485 19(2023-12-06)	Telecom	1
29	Jike	Jike protocol	Telecom	1
30	Dyness	RS485-protocol-pylon-low-voltage-V3.3-ds	Telecom	1
31	SRP	RS485-protocol-pylon-low-voltage-V3.5-rs	Telecom	1
32	EPEVER	RS485 remote temperature	Modbus	29
33	Jiataida	Jiataida software board common protocol	User Define	0x0D

Note: The battery manufacturers listed in this table are not used as a basis for recommendation and quality comment.

Note: See the user manual for more details!

# 5.RTS/BMS COM

➤ With RTS-D47K remote temperature sensor, temperature compensation for lead acid charging/discharging, ensure accurate charge/discharge control

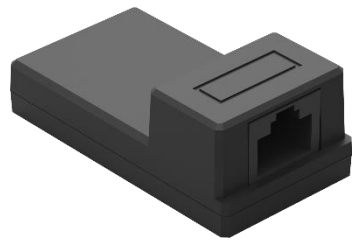
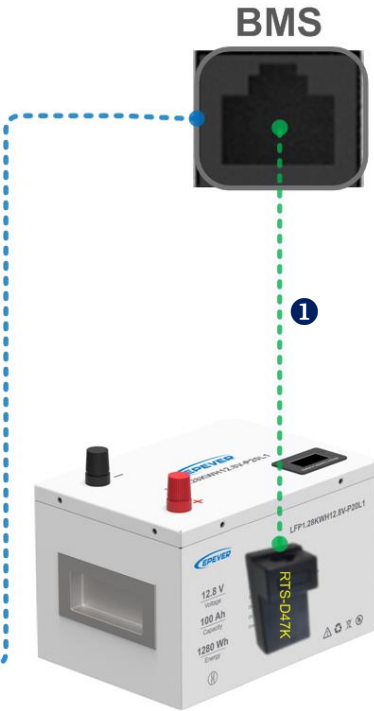

- Cable ❶ is optional, can be replaced by standard parallel network cable
- When connecting RTS-D47K, parameter "BPRO (BMS Protocol)" set to "32"(in default)

## 6. Load output

- Support 6 load modes, meet multi-scenario application needs



- **6 load control modes:** Manual, Sunset Load ON Mode, Sunrise Load ON Mode, Sunset Load ON + Timer Mode, Timer Mode, Always ON Mode
- Under Always ON Mode, load can work 24 hours a day until battery triggers the over-discharge protection.

## 7. Built-in Bluetooth

➤ Built-in Bluetooth module, convenient APP management without additional accessory

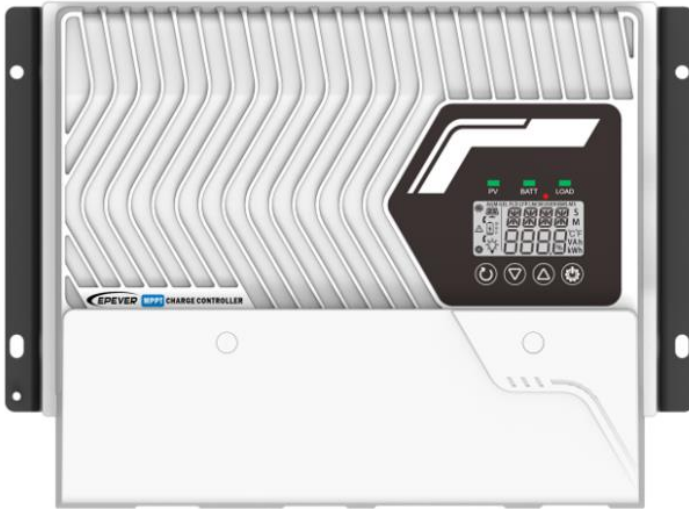

- Models with “BLE” ( IT6415NC G3 BLE, IT10415NC G3 BLE) support built-in Bluetooth
- COM port can also connect accessories (e.g, USB to RS485 cables or WiFi modules) to meet the needs of many-to-one monitoring

## 8. Local monitoring

- LCD sets most parameters without accessories, more convenient

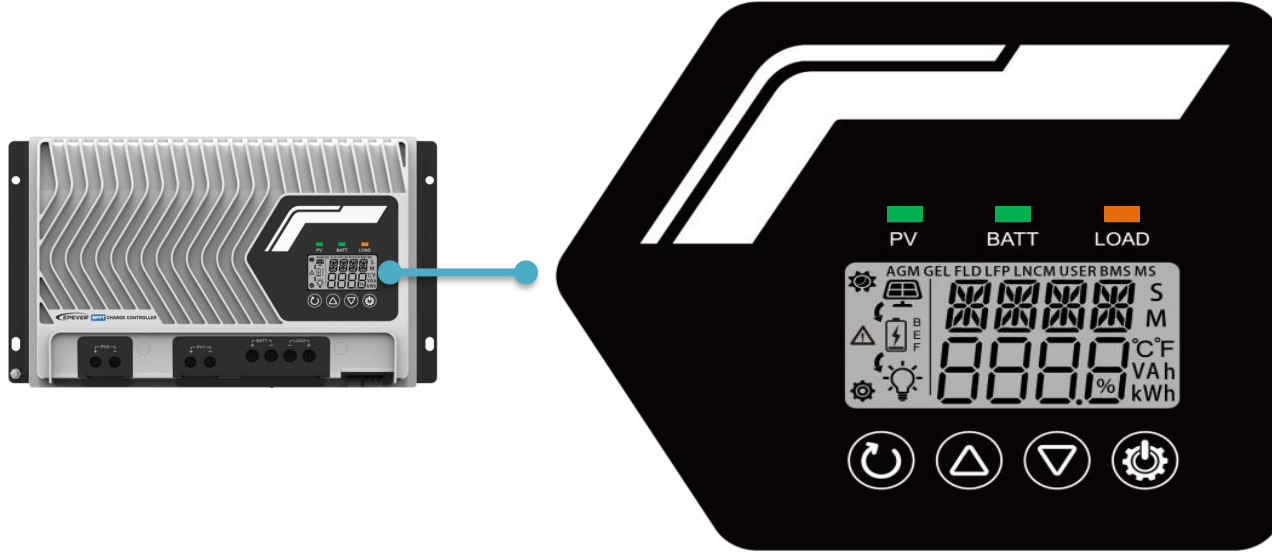

PV Status



Battery Status



Load Status

- Monitor PV, battery, load running status and real-time data, software and hardware versions, fault information of the system via LCD screen
- All load modes and control parameters can be set via LCD screen
- With one-click restore factory default function

# 9.Remote monitor

- Isolated RS485 com port: FW upgrade, Or optional Bluetooth, WIFI, 4G modules to achieve wireless monitoring



# 10.Data Log

- Real-time data, events and power recording, 15000 storage capacity, full capacity cycle coverage



- Not losing data in case of power failure;
- The data will be covered in a cycle, covering about 130 sectors after full capacity;
- Scada software (Solar Guardian) can query and download the local storage of historical data, convenient for data statistics and analysis

# 11.Work Environment

➤ Full load operation in  $-25\sim 40^{\circ}\text{C}$ , high temperature charging will automatically reduce power

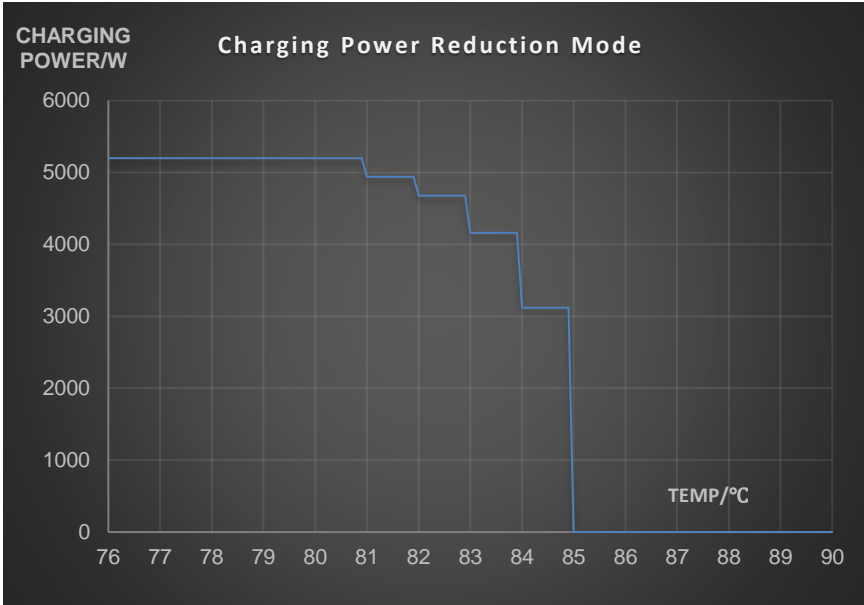

# 11. Work Environment



- Power derating curve when temperature is higher than 40°C

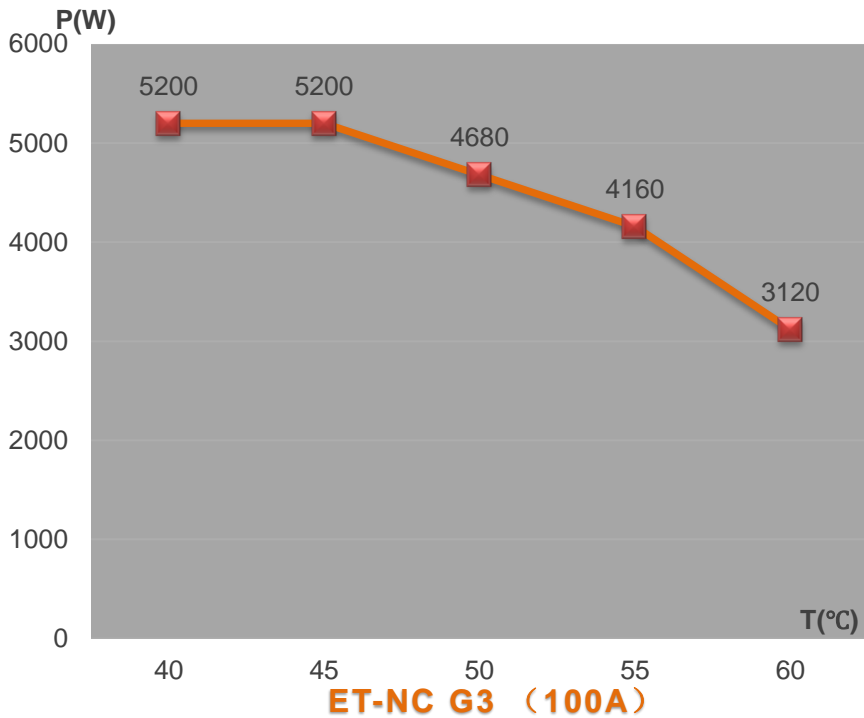
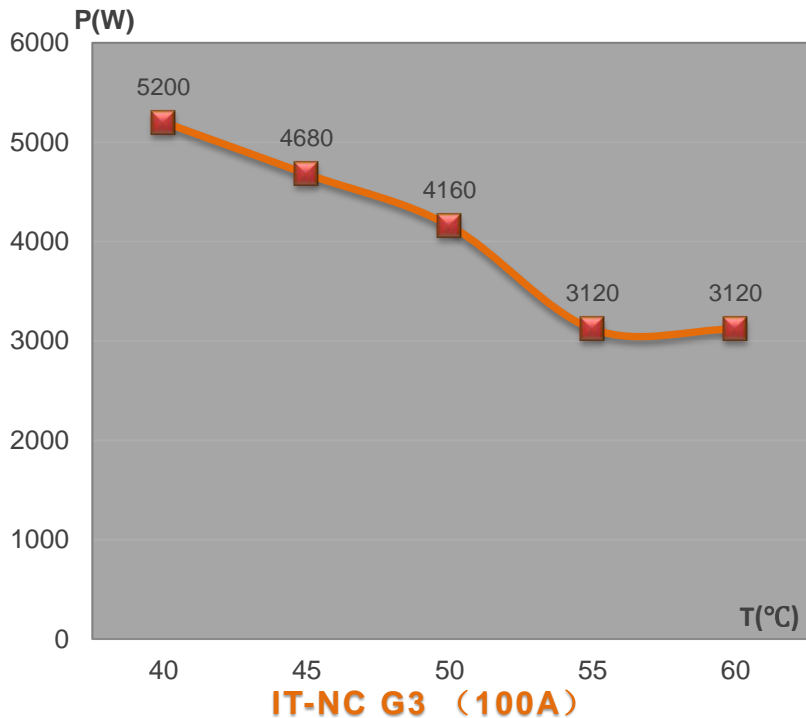

- Operating Temperature Range -25°C to +60°C (Derating when temperature is higher than 40°C)

## 12.Low Loss& High IP

- Low power consumption design, static loss < 50mA
- All metal die-cast casing, IP43, IP32 protection level optional



IP43



IP32

- Low power consumption design meets ultra-compact system configuration and longer standby time
- Dustproof level-4: prevent the entry of solid foreign objects larger than 1.0 mm; Level-3: prevent the entry of solid foreign objects larger than 2.5 mm
- Waterproof level-3: Prevent water from falling within an angle of 60 degrees from the vertical direction; Level-2: Prevent water from dripping when tilted at 15 degrees.

# 13.Certification



## ➤ Designed with IEC62109, UL1741, EMC(ClassB) high certification standards

COMPLIANCE



### VERIFICATION OF COMPLIANCE

Verification No.: GZEM2409005542PVV  
 Applicant: Huizhou Epever Technology Co., Ltd.  
 Address of Applicant: No. 103, Dongxing Rd, Chenjiang Street, Zhongkai High-Tech Zone, Huizhou, China  
 Manufacturer: Huizhou Epever Technology Co., Ltd.  
 Address of Manufacturer: No. 103, Dongxing Rd, Chenjiang Street, Zhongkai High-Tech Zone, Huizhou, China  
 Product Name: Solar Charge Controller  
 Model No.: IT10420NC G3, IT10415NC G3, IT8420NC G3, IT7420NC G3, IT7415NC G3, IT6420NC G3, IT6415NC G3, IT5420NC G3, IT5210NC G3, ET10420NC G3, ET7420NC G3, ET5420NC G3  
 Trade Mark: EPEVER  
 Standard(s): EN IEC 61000-6-1:2019  
 EN IEC 61000-6-3:2021  
 Report Number(s): GZEM240900554201

This Verification of EMC Compliance has been granted to the applicant based on the results of the tests, performed by laboratory of SGS-CSTC Standards Technical Services Co., Ltd. on the sample of the above-mentioned product in accordance with the provisions of the relevant specific standards under Directive 2014/30/EU. The CE mark can be used, under the responsibility of the manufacturer, after completion of an EU Declaration of Conformity and compliance with all relevant EU Directives.



Jerry Chan  
 Technical Manager  
 SGS-CSTC Standards Technical Services Co., Ltd.

2024-11-27

The document is issued by the Company under its General Conditions of Service available at [www.sgs.com](http://www.sgs.com). Attention is drawn to the limitation of liability, indemnification and jurisdiction therein (see Section 10).  
 Any request of this document is accepted and information provided herein reflects the Company's knowledge at the time of its production only and within the limits of Client's specifications. As a result, the Company's liability is accordingly limited and shall not extend to any products or services not covered by the Client's specifications. The Client is responsible for the accuracy, validity and completeness of the information and data provided. The Client is also responsible for the accuracy and completeness of the information and data provided. The Client is also responsible for the accuracy and completeness of the information and data provided. The Client is also responsible for the accuracy and completeness of the information and data provided.

SGS-CSTC Standards Technical Services Co., Ltd.  
 100, Chenyuan 1st Road, Huizhou, Guangdong, P.R. China  
 (China Office)  
 (0752) 2222222  
 Website: [www.sgs.com](http://www.sgs.com)  
 Number of the SGS Group (SGS-USA)  
 ENC-VOC-FSR Rev.2.0 (2014-03-25)  
 Page 1 of 1



### VERIFICATION OF COMPLIANCE

This Verification of Compliance is granted to below applicant for following designated equipment  
 Verification No.: GZEM2409005543PVV  
 Applicant: Huizhou Epever Technology Co., Ltd.  
 Address of Applicant: No. 103, Dongxing Rd, Chenjiang Street, Zhongkai High-Tech Zone, Huizhou, China  
 Manufacturer: Huizhou Epever Technology Co., Ltd.  
 Address of Manufacturer: No. 103, Dongxing Rd, Chenjiang Street, Zhongkai High-Tech Zone, Huizhou, China  
 Product Name: Solar Charge Controller  
 Model No.: IT10420NC G3, IT10415NC G3, IT8420NC G3, IT7420NC G3, IT7415NC G3, IT6420NC G3, IT6415NC G3, IT5420NC G3, IT5210NC G3, ET10420NC G3, ET7420NC G3, ET5420NC G3  
 Trade Mark: EPEVER  
 Report Number(s): GZEM240900554301

Based on tests conducted by SGS-CSTC Standards Technical Services Co., Ltd. on submitted samples of above mentioned product and found to comply with the technical requirements set out in ANSI C63.4 & 47 CFR PART 15B regulations for the evaluation of electromagnetic compatibility.

**Please note:**

- (1) Applicant and/or manufacturer shall fully fulfill FCC SDoC authorization procedure set out in 47 CFR §2.906, §2.909, §2.925, §2.1074, §2.1077.
- (2) Applicant and/or manufacturer shall comply additional requirements set out in §15.21, §15.105 and §15.119 to fully comply regulation 47 CFR Part 15.
- (3) This VoC is ONLY a conclusion of test result; ONLY serves as technical specifications compliance verification for aforementioned product from SGS Lab.
- (4) This verification is only valid for the equipment and configuration described, in conjunction with the test report detailed above.



Jerry Chan  
 Technical Manager  
 SGS-CSTC Standards Technical Services Co., Ltd.

2024-11-27

The document is issued by the Company under its General Conditions of Service available at [www.sgs.com](http://www.sgs.com). Attention is drawn to the limitation of liability, indemnification and jurisdiction therein (see Section 10).  
 Any request of this document is accepted and information provided herein reflects the Company's knowledge at the time of its production only and within the limits of Client's specifications. As a result, the Company's liability is accordingly limited and shall not extend to any products or services not covered by the Client's specifications. The Client is responsible for the accuracy, validity and completeness of the information and data provided. The Client is also responsible for the accuracy and completeness of the information and data provided. The Client is also responsible for the accuracy and completeness of the information and data provided. The Client is also responsible for the accuracy and completeness of the information and data provided.

ENC-VOC-FSR Rev.2.0 (2014-03-25)  
 Page 1 of 1



中国合格  
 评定国家  
 认可  
 实验室  
 注册号  
 CNAS L1916



### Verification Report

Report No. A2240558558101

Page 1 of 112

### CENTRE TESTING INTERNATIONAL



Company Name: HUIZHOU EPEVER TECHNOLOGY CO., LTD.  
 Address: NO. 103, DONGXING RD, CHENJIANG STREET, ZHONGKAI HIGH-TECH ZONE, HUIZHOU CITY, CHINA

**Conclusion**

Tested Sample	According to standard/directive	Result
Submitted Sample	RoHS Directive 2011/65/EU with amendment (EU) 2015/863	PASS

PASS means that the result is shown on the report comply with the limits set by RoHS Directive 2011/65/EU with amendment (EU) 2015/863.



Ophelie Wan  
 Ophelie Wen  
 Authorized Signatory  
 Centre Testing International Group Co., Ltd.  
 C.T.I. Building, Xinyuan Long Community, Xin'an Sub-district, Bao'an District, Shenzhen City, Guangdong Province, P.R. China

Date: Nov. 25, 2024

No. R1797536R2

# 14. Protections

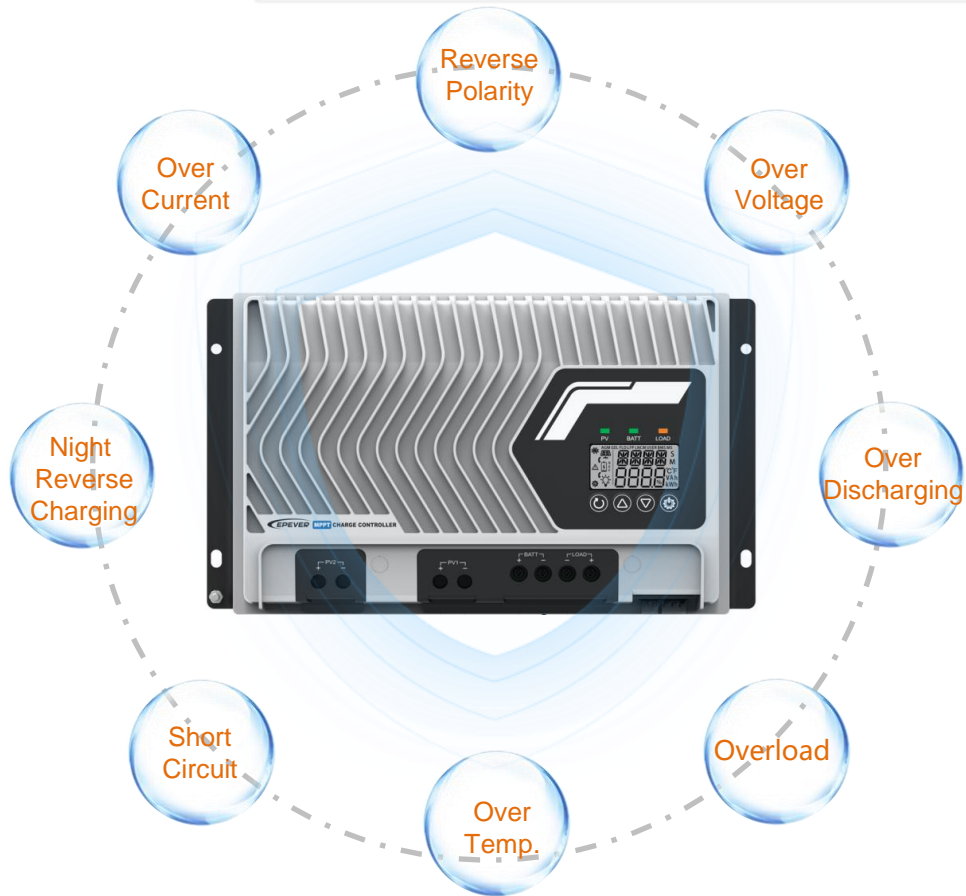

# 15.Applications

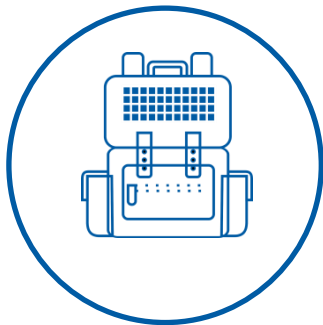

Solar Camping



Solar  
Household

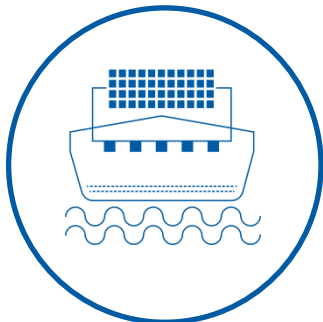

Solar Yacht



Solar RV

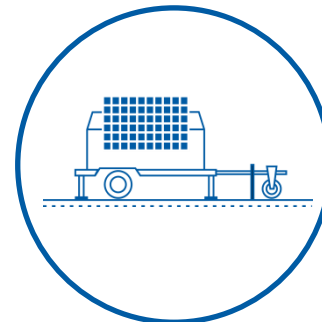

Solar  
Power Station



**Others**





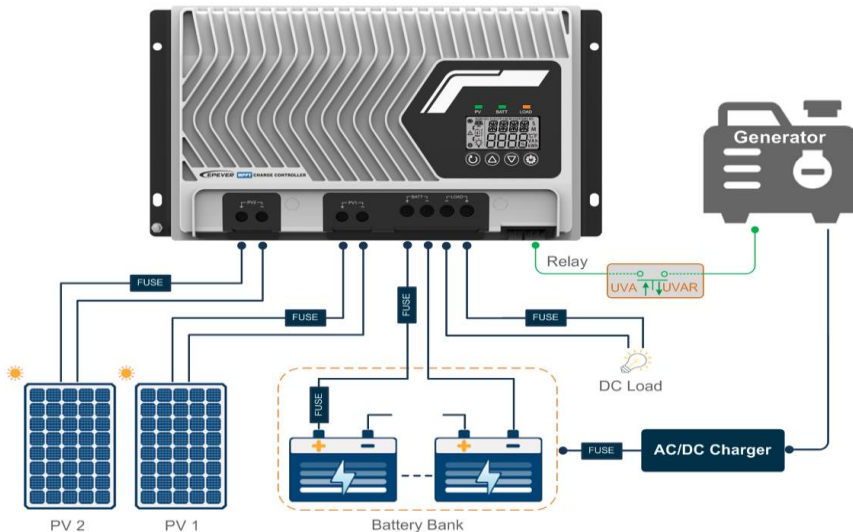
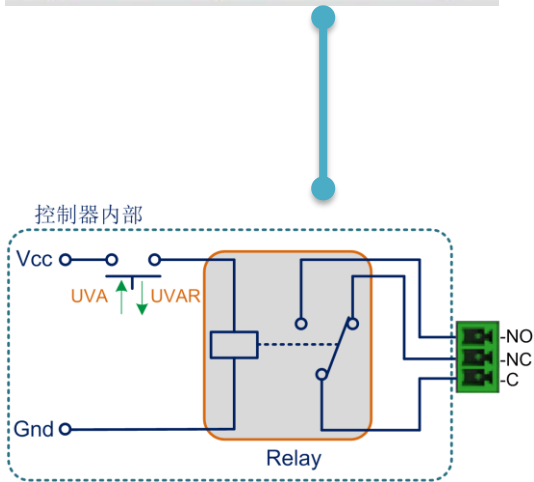
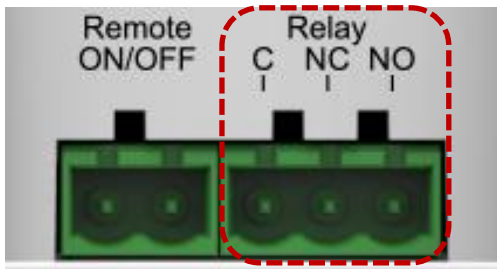

# 1. Dry contact port

## Automatically control auxiliary charging device depending on battery voltage









- Relay built-in PCB board, this port is only the auxiliary contact of the relay (passive switching signal);
- Controlled by "UVA (undervoltage alarm recovery voltage)" and "UVAR (Undervoltage alarm recovery voltage)";
- Applicable circuit parameters: rated 5A/30VDC, maximum: 0.5A/60VDC;
- Controller can automatically control the external auxiliary charging device to enter or exit charging according to the battery voltage.



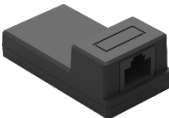

## 2.Optional Accessories

No.	Name	Model	Image	Application	Software Download
1	Remote Meter	MT53		Remote monitoring and real-time parameter configuration for the controller via wired remote connection. Plug and play without the need for any communication parameters setup. Easy and convenient operation	/
2	USB to RS485 communication cable	CC-USB-RS485-150U		①Real time monitoring, parameter settings, and historical data query and export of the device can be achieved through PC software ②Device Firmware upgrade	<a href="http://www.epsolarpv.com.cn/downsoft.html">http://www.epsolarpv.com.cn/downsoft.html</a> SolarGuardian
3	WiFi 2.4G adapter	EPEVER WiFi 2.4G RJ45 D		Compatible with mobile app or cloud platform (offline mode & online mode) for wireless monitoring and parameter configuration of the controller via WiFi signal	  Apple App Store      Google Play
4	Bluetooth adapter	EPEVER BLE RJ45 D		Compatible with mobile app or cloud platform (offline mode only) for wireless monitoring and parameter configuration of the controller via Bluetooth signal	
5	BMS protocol converter	BMS-Link		The BMS protocol of different lithium battery manufacturers is converted into our standard protocol, achieve communication and management with the controller	/

## 2.Optional Accessories

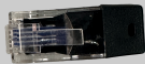
No.	Name	Model	Image	Application	Software Download
6	Serial Device Server	EPEVER TCP 306		Compatible with mobile app or cloud platform for remote wireless monitoring and parameter configuration of the controller via TCP network communication. Using PC configuration tools and PC software to LAN monitoring	 
7	Wireless remote terminal unit	EPEVER RTU 4G HE01		Compatible with mobile app or cloud platform for remote wireless monitoring and parameter configuration of the controller via a GSM/GPRS SIM card	 
8	Logger	eLOG01-G3		Record the historical data and status of the controller, can be queried or downloaded through PC software Solar Guardian, convenient for users to do data statistics and analysis	<a href="http://www.epsolarpv.com.cn/downsoft.html">http://www.epsolarpv.com.cn/downsoft.html</a> SolarGuardian
9	Remote temperature sensor	RTS-D47K		Use with CC-RJ-RJ-120 cable, collect the battery temperature, and the controller can performs accurate control and protection of charging and discharging.	/

## 2.Optional Accessories

No.	Name	Model	Image	Applicaition	Remark
10	CAN communication terminal resistor	RJ45-CAN-R120		When multiple controllers are connected in parallel, the terminal resistors should be installed on the parallel communication port of first and last controllers.	When multiple devices are paralleled, they are installed on the parallel communication port of the first and last controller. Number = 2pcs
11	RS485 communication cable, parallel communication cable	CC-RJ45-RJ45-120		1.Used for parallel communication of multiple controllers ; 2.For connecting remote temperature sensor	Number =(number of parallel machines -1) pcs Note: Standard network cable can be used instead
12	RS485 to RS485 communication cable	CC-RJ45-RJ45-150		Used for communication connection between the controller and EPEVER Lithium battery	The BAT side of the cable is connected to the communication port of the EPEVER battery, and the OUT side of the cable is connected to the BMS port of the controller
13	RS485 to RS485 communication cable	CC-RJ45-RJ45-PYLON-200		Used for communication connection between the controller and Pylontech lithium battery	TO PYLON BATTERY label side connects to the Com port of Pylontech Li-battery, TO EPEVER INVERTER label side connects to the BMS Com port the controller

### 3.Fan control

Control condition	Fan status	Noise dB(A)
1.Internal temperature>70°C 2.Internal temperature>32°C <b>and</b> Charge current > Rated current/3	Start	<47dB
1.Internal temperature < 30°C 2.Internal temperature < 65°C <b>and</b> Charge current < Rated current/4	Stop	<20dB
<b>Note: Only IT10415NC G3、IT10420NC G3、IT10415NC G3 BLE with Fans, other models are naturally cooled and with lower noise.</b>		

## 4. Comparison

### IT-NC G3 VS ET-NC G3 series

Item Series	Model	Built-in Bluetooth	Load output
ET-NC G3	ET5420NC G3 ET7420NC G3 ET10420NC G3	×	×
IT-NC G3	IT5420NC G3 IT6415NC G3、IT6420NC G3 IT7415NC G3、IT7420NC G3 IT8420NC G3、IT10415NC G3、IT10420NC G3 IT6415NC G3 BLE、IT10415NC G3 BLE	√ (IT6415NC G3 BLE、 IT10415NC G3 BLE)	√

## 4.Comparison

### IT-NC G3 VS Tracer-AN(50A-100A)series

NO.	Item/series	Tracer-AN (50A~100A)	IT-NC G3 series
1	Exterior	Plastic housing	√ (All metal die-cast casing)
2	Enclosure	IP20	√ (IP43/IP32)
3	Local settings	Just only default battery types	√(LCD can set most parameters)
4	Built-in Bluetooth	×	√(part models support)
5	Dual MPPT	×	√(80A&100A models support)
6	Constant Volt Output	×	√ (PV can supply load directly without battery)
7	Multi-unit parallel	√ (PT-ADP module is required)	√ (CAN com. cable and terminal resistor are required)
8	BMS communication	×	√ (BMS-Link module is required)
9	Data log	×	√
10	Load output	×	√
11	COM enable control	×	√(Low loss)
12	Static loss	×(<100mA)	√(<50mA)
13	EMC Certification	× (Class B, test without full load)	√(Class B, test with full load power)



# Thank

# you

 BLDG#18, CO.PARK, NO.8 HEYING ROAD, CHANGPING DISTRICT, BEIJING, CHINA

 010-82894112  010-82894882  [www.epever.com](http://www.epever.com)  [info@epsolarpv.com](mailto:info@epsolarpv.com)